



CODIAN
ROBOTICS

**LOGICAL INNOVATION FOR
PICK AND PLACE ROBOTICS**

D4-800-HD/D4-1100-HD/D4-1300-HD

The Codian Robotics 100% hygienic design D4-800-HD/D4-1100-HD/D4-1300-HD, three- or four-axis delta robots are specially designed for high speed toploding pick & place processes with open food, chemical or pharmaceutical products. The special surface treatment of the robot housing with ViwateQ finishing against the growth of microorganism and the IP69K protection make the robot unique in its kind.

The parallel kinematics design is clean, fast and silent. The D4-800-HD/D4-1100-HD/D4-1300-HD delta pick & place robots are designed to perform with payloads up to 3 kg and have a working envelope of Ø 800/1100/1300 mm. The robots can be controlled by many different PLC and motion control systems. Combined with a vision system, they can also be used for random and/or mixed product flow picking.

- Open platform for servo motors and control systems
- Materials: titanium, 316L stainless steel, sanitary plastic, ViwateQ finishing
- Suitable for certain Clean Room applications
- Fully enclosed system for gearboxes, servo motors and cables
- Low maintenance, easy access to inner components
- Smooth seamless rounded surface, easy to clean, CIP (Cleaning In Place)
- IP69K
- All materials are FDA approved



CODIAN
ROBOTICS

D4-800-HD/D4-1100-HD/D4-1300-HD

THE NEW STANDARD FOR PICKING AND PLACING

SPECIFICATIONS

Kinematic structure:	delta type
Degrees of freedom:	3+1*
Protection:	IP69K
Noise level:	< 68 dB(A)
Weight:	100 kg

*with optional rotation axis

PERFORMANCE

Rated working range:	Ø 800/1100/1300 x 250 mm (see drawing)
Payload:	3 kg
Pick and Place actions	
D4-800-HD:	max. 180 p/min
D4-1100-HD:	max. 150 p/min
D4-1300-HD:	max. 120 p/min
Position repeatability X,Y,Z:	± 0.1mm
Rotation axis Rz (optional):	angle unlimited angular repeatability Rz ± 0.3 ° limitation rotation axis torque 16 Nm

WORKING AREA

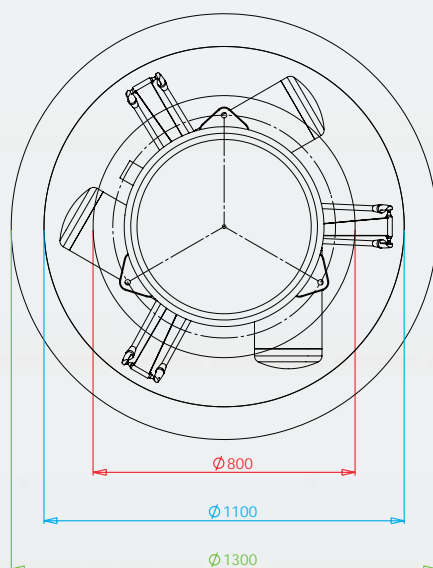

800 = D4-800-HD
1100 = D4-1100-HD
1300 = D4-1300-HD

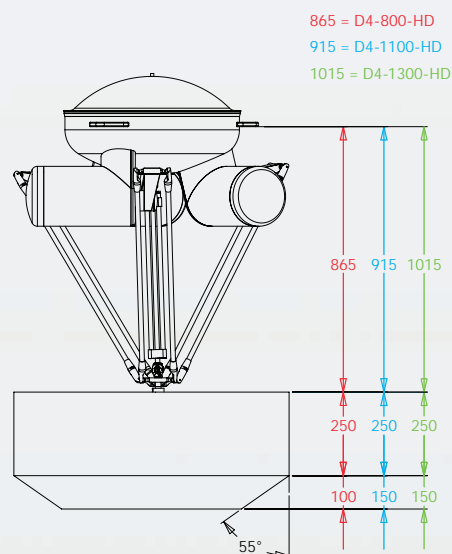

865 = D4-800-HD
915 = D4-1100-HD
1015 = D4-1300-HD

